



Single Built in Oven

Users Guide
&
Installation & Servicing

www.rangemaster.co.uk

Contents

Safety Instructions	3
Before first use	3
The Facia Panel	4
Oven accessories	4
Oven operation	4
 Oven temperature	6
Oven cooking chart	7
Grilling in the oven	8
Grilling cooking chart	8
Cleaning and care	10
Solving problems	12
Installation	13
Technical Data	16

Safety Instructions

Please read these operating instructions carefully for full information on the safe installation, use and care of your new Rangemaster appliance.

- This appliance must be correctly installed in accordance with the manufacturer's instructions by a suitably qualified person.
- We cannot accept responsibility for damage to persons or items due to poor or incorrect installation of this appliance.
- Make sure that the voltage and frequency of the mains supply correspond to the details on the rating plate which can be found on the lower part of the front of the oven.

Warning: this appliance must be earthed.

- We cannot accept any liability for failures in the earth connection or for earth connection that is not in compliance with the regulations in force.
- Maintenance and servicing work must only be carried out after the power supply has been disconnected by switching off at the on/off isolator or removing the mains fuse.
- Due to our policy of continuous innovation, we reserve the right to adjust or modify our product without prior notification.
- Do not use the oven to heat kitchen, not only does this waste fuel but the control knobs may become overheated.
- Do not let children near the oven during use to avoid the danger of burns or injury. Supervise the use of the oven by the elderly or infirm.

- Never store flammable materials in a drawer or cupboard beneath a built-in oven as there is a risk of fire.
- Do not place heavy objects on the open door or sit on it as this could cause damage to the hinging.
- To avoid damage to the interior enamel, do not place the oven pan or baking trays on the bottom of the oven and do not line the base of the oven with aluminium cooking foil.
- During cooking, food naturally produces steam, which is vented away to prevent an excessive build-up within the oven. As this steam can condense to water droplets on the cool outer trim of the oven, it may be necessary during cooking to wipe away any moisture with a soft cloth. This will also help to prevent soiling and discoloration of the oven exterior by cooking vapours.

Before first use

Before using for your oven for the first time clean it thoroughly. Switch off the oven at the on/off isolator or remove the mains fuse before cleaning. Remove any packaging and the oven accessories from the ovens. Wipe the oven interior using hot water and a mild detergent. Rinse carefully using a damp cloth. Wash the oven shelves and accessories in a dishwasher or using hot water and a mild detergent, and dry thoroughly.

Slide the oven shelves and the oven pan onto the runners, close the doors and heat the ovens to maximum temperature for 30 minutes to eliminate any residues from the manufacturing process.

USERS GUIDE

The Facia Panel

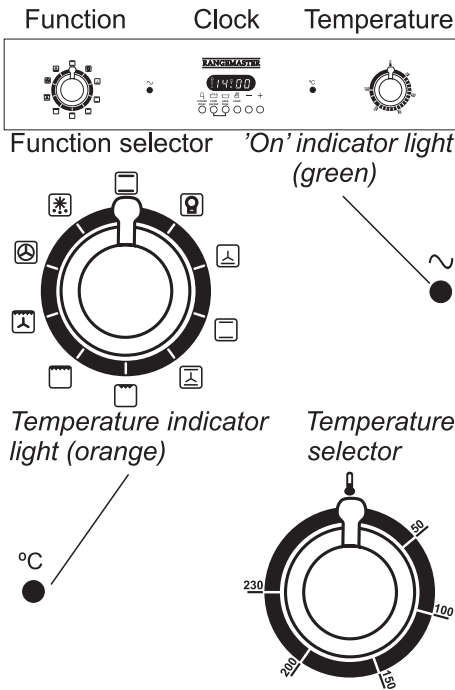

Oven accessories

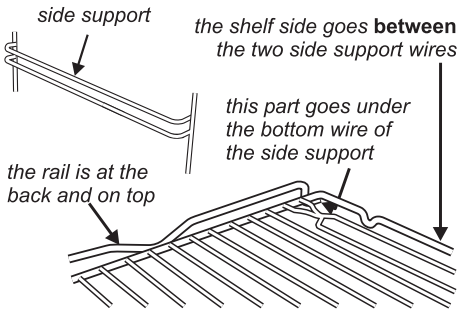

The oven is supplied with a full range of accessories. Depending on the model, this comprises either 2 or 3 wire shelves, 2 enamelled oven pans with 2 trivets and a handle. The wire shelves and oven pans slide into the shelf supports located on either side of the oven interior (see

diagram). The shelf must be located the right way up. See the figure.

The shelf supports are numbered from 1-5, position 1 being the lowest.

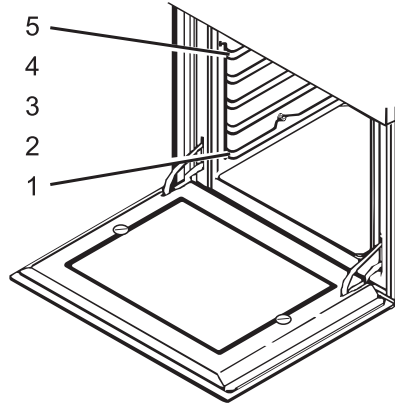

The oven pan can be used for roasting or grilling in the oven. When grilling, fit the handle to the oven pan to slide it in or out of the oven.

Oven operation

Your new Rangemaster oven incorporates a multifunction cooking system, enabling you to select the most appropriate heating method for the type of food you are preparing. We suggest you keep a careful eye on your cooking until you are familiar with each function. Remember - not all functions will be suitable for all food types. Please remember that all cookers vary - temperatures in your new oven may differ to those in your previous cooker.

The function required is selected by turning the oven function selector knob in a clockwise direction to the chosen symbol. The interior light of the selected oven will illuminate and the 'On' indicator light will glow. The oven functions and their symbols are:

USERS GUIDE



Light only

The oven interior light comes on.



Base heat plus fan

The fan operates with the element under the floor of the oven. The oven should be pre-heated before use until the temperature indicator light goes out.

This function is ideal for baking quiches and pastry tarts so that the base of the item cooks and crisps. In this case, the food should be cooked with the oven shelf on the lowest shelf position.



Conventional oven (top and base heat)

This function combines the heat from the top and base elements. It is particularly suitable for roasting and baking pastry, cakes and biscuits.

The oven should be pre-heated before use until the temperature indicator light goes out. It is recommended that food is only placed on one shelf position when cooking with the conventional heating function. Do not use the lowest or highest shelf positions or the food may overcook.



Fan assisted oven

This function operates the fan, circulating air heated by the elements at the top and the base of the oven. The combination of fan and conventional cooking (top and base heat) makes this function ideal for cooking large items that need thorough cooking, such as a large meat roast. It is also possible to bake on two shelves at one time,

although they will need to be swapped over during the cooking time, as the heat at the top of the oven is greater than at the base, when using this function.

This is a fast intensive form of cooking; keep an eye on the food cooking until you have become accustomed to this function.



Single Circuit Grill

The centre of the grill element in the roof of the oven operates. The oven should be pre-heated for 5-10 minutes before use. The oven pan should be used on one of the upper shelf positions. Fit the handle when sliding the oven pan in or out of the oven. *Grilling must always take place with the oven door closed in order to ensure correct performance of this function. Check your food regularly to avoid over cooking.*



Dual Circuit Grill

Same procedure as single circuit grill, but the whole grill element operates giving you a larger area for grilling.



Fanned grilling

This function operates the fan whilst the top grill element is on. It produces a more even, less fierce heat than a conventional grill. For best results, place the food to be grilled, on a grid over a roasting tin, which should be smaller than a conventional grill pan. This allows greater air circulation. Thick pieces of meat or fish are ideal for grilling in this way, as the circulated air reduces the fierceness of the heat from the grill. The oven door should be kept closed whilst grilling is in progress, so

USERS GUIDE

saving energy. You will also find that the food needs to be watched and turned less than for normal grilling. Pre-heat this function before cooking.



Fan oven

This function operates the fan and the heating element around it. An even heat is produced throughout the oven, allowing you to cook large amounts quickly.

Fan oven cooking is particularly suitable for baking on several shelves at one time and is a good 'all-round' function. It may be necessary to reduce the temperature by approximately 10°C for recipes previously cooked in a conventional oven.

If you wish to pre-heat the oven, wait until the indicator light has gone out before inserting the food.



Defrost

This function operates the fan to circulate cold air only. No heat is applied. This enables small items such as desserts, cream cakes and pieces of meat, fish and poultry to be defrosted.

Defrosting in this way speeds up the process and protects the food from flies. Pieces of meat, fish and poultry should be placed on a rack, over a tray to catch any drips. Be sure to wash the rack and tray after defrosting.

Defrost with the oven door closed.

Large items, such as whole chickens and joints should **not** be defrosted in this way. We recommend this be carried out in a refrigerator.

Defrosting should not be carried out in a warm oven.

Ensure that dairy foods, meat and poultry are completely defrosted before cooking.



Oven temperature

The oven temperature is set by turning the appropriate oven temperature selector knob clockwise to the required level. An oven temperature must be set for all functions except defrost and light. Temperatures can be set from 50°C to 250°C. Once a temperature has been selected, the appropriate temperature indicator light will glow. When the oven has reached the required temperature, the light will go out. If pre-heating is recommended, food can now be placed in the oven. During cooking, the light will occasionally glow as the heating element(s) operate to maintain the oven temperature. The temperature selector should be reset to zero by turning anti-clockwise after use.

Temperature Conversion Chart

In order to convert existing recipes for use in your oven, use this chart as a guide.

Gas	°F	°C
1	275°F	140°C
2	300°F	150°C
3	325°F	160°C
4	350°F	180°C
5	375°F	190°C
6	400°F	200°C
7	425°F	220°C
8	450°F	230°C
9	475°F	240°C

COOKING GUIDE

Oven cooking chart

Food	Conventional Oven			Fan Oven		
	Temp °C	Shelf Position	Cooking time/mins.	Temp °C	Shelf Position	Cooking time/mins
Victoria sponge	180	2	20-25	160	1 or 1 & 2	25-30
Scones	230	1	10-15	210	1 or 1 & 2	10-15
Small sponge cakes	180	2	15-20	160	1 or 1 & 2	15-20
Shortcrust pastry	200	1	30-45	180	1	35-45
Choux pastry	200	1	20-30	180	1 or 1 & 2	25-35
Puff or flaky pastry	230	1	15-30	210	1 or 1 & 2	20-35
Biscuits	200	2	10-15	180	1 or 1 & 2	15-20
Bread	220	1	20-40	200	1	25-45
Lasagne	200	1	30-40	180	1	35-45
Pizza	220	1	20-25	200	1	25-30
Roast beef	200	1	20-30/500g+20	180	1	20-30/500g+20
Roast pork	200	1	30/500g+30	180	1	30/500g+35
Roast lamb	190	1	25/500g+20	170	1	25/500g+25
Roast chicken	190	1	20/500g+20	170	1	20/500g+25
Roast duck	190	1	30/500g	170	1	35/500g
Roast goose	180	1	25/500g	170	1	25/500g
Roast turkey	170	1	25/500g	160	1	25/500g
Vegetable bake	200	2	30-40	180	1	35-45
Beef casserole	160	1	2-3hours	150	1	2-4hours

500g is approximately 1lb (1lb 2oz)

Fan oven Temperature Conversion Chart

When converting conventional oven recipes for use with the fan oven function, the oven temperature is reduced by approximately 10°C. The following chart gives a guide to correct temperatures in °C.

Please note that the recommendations contained in these charts are given as a guide only.

Conventional Fan Oven

50°C	50°C
75°C	70°C
100°C	90°C
125°C	100°C
150°C	125°C
175°C	160°C
200°C	180°C
225°C	200°C

COOKING GUIDE

Grilling in the oven

Depending on the amount to be cooked select either the single or dual circuit grill.

Whenever the grilling function is selected, set the appropriate temperature selector knob at maximum and pre-heat the oven for 5-10 minutes before use.

Food should be arranged on a wire shelf on one of the upper shelf positions. The oven pan should be placed into the oven with the trivet in place to collect any juices. Fit the handle to the oven pan when sliding it in or out of the oven.

Grilling must always take place with the oven door closed in order to ensure correct performance of this function. Check your food regularly to avoid over cooking.

Grilling cooking chart

Food	Temp °C	Shelf Position	Cooking time/mins.
Sausages	Max.	5	5-10/side
Bacon rashers	Max.	5	5-10/side
Burgers	Max.	5	5-10/side
Chop or steak	Max.	4 or 5	10-15/side
Chicken portions	Max.	4 or 5	10-15/side
Trout	Max.	4	10-15/side
Salmon steaks	Max.	4	5-10/side
Cheese on toast	Max.		5 - 10
Browning toppings	Max.		10 - 15

Please note that the recommendations contained in this chart are given as a guide only.

Electronic digital 24-hour clock

The oven has an electronic digital 24 hour clock and automatic timer (see diagram)

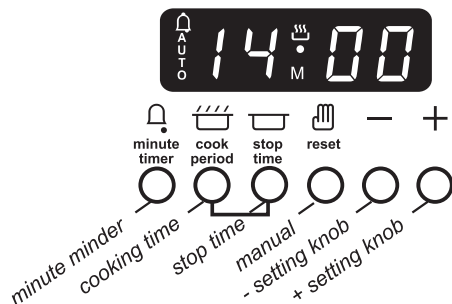

Setting the time of day

When the oven is first connected to the mains electricity supply or following a power failure, three zeros will flash in the time display. To set the time of day press and hold the (☰) and (☐) buttons and at the same time press the + or - buttons to set the correct time using the 24 hour clock system. The speed at which the digits change increases the longer the + or - button is held. Release the buttons once the time has been set to start the clock running.

Manual oven operation

In order that the oven can be used manually, the timer must be set to 'manual'. If the automatic cooking indicator (☰) is flashing, press the (☰) button until the time display reads zero then press the (☰) button again. The ☰ indicator will stop flashing. The oven can now be used manually.

Setting the minute minder

The minute minder can be used to time any period from 1 minute to 23 hours 59 minutes. To set the minute minder press and hold the (☐) button and at the same

time press the + or - buttons to set the required time. Release the buttons once the time has been set to start the minute minder running. The time display will show the time of day and the (☐) indicator will appear.

To check the remaining time on the minute minder at any point, press the (☰) button. The time display will show the remaining time on the minute minder until the button is released.

Once the time has elapsed the (☐) indicator disappears and a buzzer sounds. This can be switched off by pressing the (☐) button.

Setting the timer to turn the oven off automatically

Either: Press and hold the (☰) button and at the same time press the + or - buttons to set the required cooking time.
Or: Press and hold the (☐) button and at the same time press the + or - buttons to set the required time at which cooking should end.

Release the buttons once the time has been set. The time display will show the time of day and the (☰) and (AUTO) indicators show.



Set the oven function and temperature selector to the required positions. The oven will turn on immediately and operate for the period selected on the timer, then switch off automatically.



Once the cooking time has elapsed the (AUTO) indicator disappears and a buzzer sounds. This can be switched off by pressing the (☐) button. Turn the oven function and temperature selector knobs to zero. Press the (☰) button to reset the oven to manual operation. The

USERS GUIDE



flashing () indicator will disappear.
The oven can now be used manually.

Setting the timer to turn the oven on and off automatically





Press and hold the () button and at the same time press the + or - buttons to set the required cooking time. Release the buttons once the time has been set. The time display will show the time of day and the () and (AUTO) indicators will flash.

Now press and hold the () button and at the same time press the + or - buttons to set the time at which cooking should end. Release the buttons once the time has been set. The time display will show the time of day, the (AUTO) indicator will disappear and the () indicator will flash.

Set the oven function and temperature selector knobs to the required positions. The oven will switch on at the appropriate time, operate for the period selected on the timer, then switch off automatically. Once the oven switches on, the (AUTO) indicator will flash to show that automatic cooking is in progress.

When the oven switches off, the (AUTO) indicator disappears and a buzzer sounds. This can be switched off by pressing the () button. Turn the oven function and temperature selector knobs to zero. Press the () button to reset the oven to manual operation. The flashing () indicator will disappear. The oven can now be used manually.

Cancelling an automatic cooking programme

An automatic cooking programme can be cancelled at any moment by pressing and holding the () or () button until the time display reads zero. Press the () button to reset the oven to manual operation. The flashing () indicator will disappear. The oven can now be used manually.

Cleaning and care

Warning: Switch off the mains electricity supply to the oven during cleaning.

Control panel and oven door front

The exterior of the oven should be regularly wiped over using a soft, damp cloth and a mild detergent solution, rinsed, then dried with a soft, lint-free cloth. Do not allow water to run down the front of the appliance during cleaning. On no account should abrasive or caustic cleaning agents be used, as these would damage the surface finish.

Removing the oven door

To aid cleaning and make access to the oven interior easier, the oven door can be simply removed (see diagram).

To facilitated cleaning of the oven, the door can be removed via the hinges as follows.

Hinges with locking toggle

The hinges A, have locking toggles B. Fully open the door and swivel the locking toggles on both hinges forward to the locking position.

USERS GUIDE

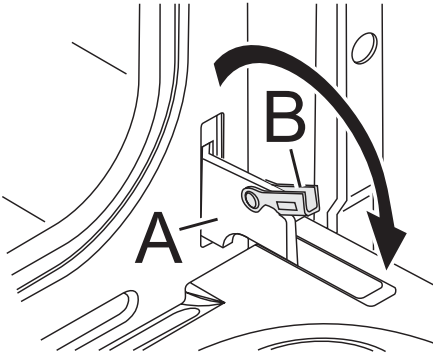

Grip the sides of the door and lift it upwards and slide it forward to remove. To refit the door, slide the hinges into their slots. Before closing the door, **remember to rotate the two toggles B**, used to lock the two hinges, fully back.

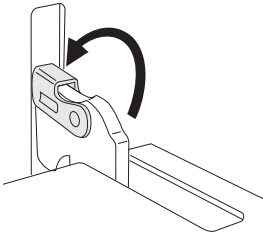

Do not immerse the door in water

Clean the enamelled interior surface and the glass using a damp cloth and a proprietary mild cream cleaner, rinse, then dry carefully using a soft cloth. If necessary, the inner door glass can be removed by unscrewing the two fixing screws. Make sure that the glass is dried thoroughly before re-fitting. Take care not to over tighten the fixing screws when re-fitting.

Removing the shelf support

Some models have detachable shelf support, which can be removed, from the oven for cleaning by hand or in a dishwasher. Grasp the shelf support and press downwards to release from the clip device on the lowest runner (see diagram).

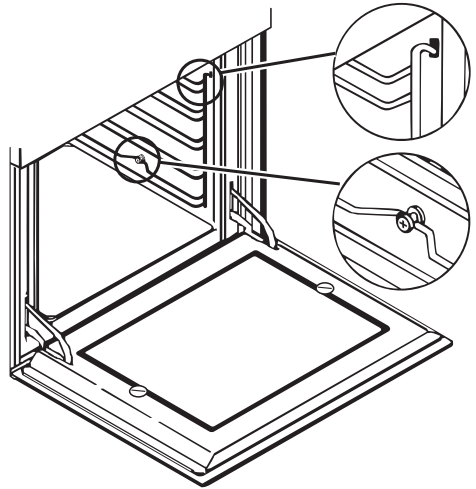

The shelf support can then be hinged upwards and lifted from the mounting holes in the upper corners of the oven prior to removal. To re-fit the shelf supports, reverse the procedure ensuring that the clip device engages firmly on the lowest runner.

Oven accessories

The oven shelves, oven pans and trivets should be washed in hot water with a mild detergent then dried carefully, or they can be washed in a dishwasher.

Cleaning the oven interior

The interior of the oven has an enamelled finish. In order to make cleaning easier, any spillage's should be wiped away as soon as possible after they occur. Clean the enamelled interior surfaces using a damp cloth and a proprietary mild cream cleaner, rinse, then dry carefully using a soft cloth. Any burnt-on soiling can be carefully removed using a plastic scourer.

Do not use caustic or abrasive cleaning agents, knives or other metal implements as these could damage the oven.

USERS GUIDE

Catalytic stay-clean liners (optional extra)

Catalytic stay-clean liners for the sides and rear of the oven only are available as an optional extra for some models.

Please contact your Rangemaster dealer for details. With catalytic liners fitted, only the roof, floor and door of the oven require conventional cleaning (see page 11). Splashes from food onto the side and rear panels are broken down during normal use of the oven at temperatures above 200° C, so little manual cleaning should be necessary. Do not use any type of cleaning agent on the catalytic linings or permanent damage could occur. In cases of heavy soiling (e.g.: after roasting or grilling fatty meat) the oven can be cleaned using an additional special process. Clean the enamelled and glass parts of the oven interior and remove the shelf supports (see page 11). Close the door and switch on the oven using the fan assisted oven setting at the maximum temperature for 1- 1½ hours, depending on the level of soiling.

Cleaning the oven interior

Once the oven has cooled, the base can be wiped with a damp cloth and the shelf supports replaced (see page 11).

Solving problems

This appliance must only be repaired by a qualified technician appointed by the manufacturer. Unauthorised repairs could be dangerous and would invalidate any warranty.

Minor faults can be remedied as follows:

The oven does not work at all.

Check that the electricity supply is connected and switched on.

Has the fuse blown? If so, have the fuse replaced with the correct type.

The oven does not heat up

Has a temperature been set using the temperature selector knob?

Has the defrost function been selected ? These functions do not operate with heating elements.

Is the oven set to automatic operation (see pages 9-10)?

The oven heats up but the light bulb does not work

The light bulb is faulty and needs replacing. Please note that light bulb failure is not covered under the manufacturer's warranty.

Replacing the oven light bulb

Warning : Switch off the mains electricity supply to the oven.

The oven light is positioned in the top left hand corner of the oven interior. If the light bulb needs replacing, unscrew the protective cover by turning it anticlockwise and remove the faulty bulb (see diagram).

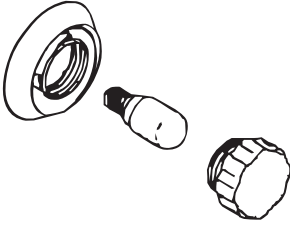

Fit the replacement bulb and replaced the protective cover, screwing it firmly into place.

The catalytic liners (if fitted) are heavily soiled and difficult to clean.

To ensure that the stay-clean linings operate effectively, the oven should be heated to at least 200°C whenever heavy soiling has occurred during roasting or grilling. If this is not done, the soiling burns onto the linings and they become black and shiny. In this case new liners must be purchased from your Rangemaster dealer. For after sales service see the 'Customer Care' leaflet.

Installation

Warning: This appliance must be correctly installed by a suitably qualified person strictly in accordance with the manufacturer's instructions. The manufacturers decline responsibility for injury or damage to person or property as a result of improper installation of this appliance.

This appliance conforms to DC No 13/4/89 and the standards of CEE DTD 87/308 of 2/6/1987 regarding the elimination of radio interference.

Electrical connection

Electrical Installation must comply with all relevant local and national regulation. Make sure that the voltage supply is the same as the rating given on the data plate positioned on the lower part of the front of the oven. This appliance must be connected to an A.C. single phase 230 V, 50 Hz electricity supply. The total rated load is 2,95 kW. The oven must be connected to a 16 amp power supply via a suitable isolator with an on-off switch, and protected by a 16 amp fuse. The isolator should be easily accessible in case of maintenance or emergency. A suitable cable, which complies with all local and national regulations, must be used. This should be of type H05 RR-F, 3- core, and with a minimum sectional area of 1,5 mm.

The connection clamp for the cable is at the rear of the appliance. Unscrew and remove the cover then insert the cable by way of the cable clip and connect.

Warning: This appliance must be earthed.

The earth conductor of the mains cable must be longer than the other two conductors; in order that the it would become disconnected last should the cable be pulled or work loose following installation. Secure the cable by tightening the cable clip screws fully, then replace and secure the cover.

USERS GUIDE

Built-in installation

This appliance is designed for building-in to a standard 600mm wide oven housing. The housing, adjacent furniture and all materials used in installation must be able to withstand a minimum temperature of 80°C plus ambient temperature during periods of operation. In addition, adjacent furniture cabinet doors must be at least 8mm from the appliance at all points. Certain types of vinyl or laminate kitchen furniture cabinetry are particularly prone to heat damage and discolouration, any delamination or discolouration of materials which occurs below 80°C plus ambient temperature or where materials are less than 8mm from the appliance

will be the liability of the owner. The housing into which the appliance is installed must incorporate a full depth shelf positioned 85 : 90mm below the support shelf for the appliance. For building-under a worktop, the installation dimensions are as follows:

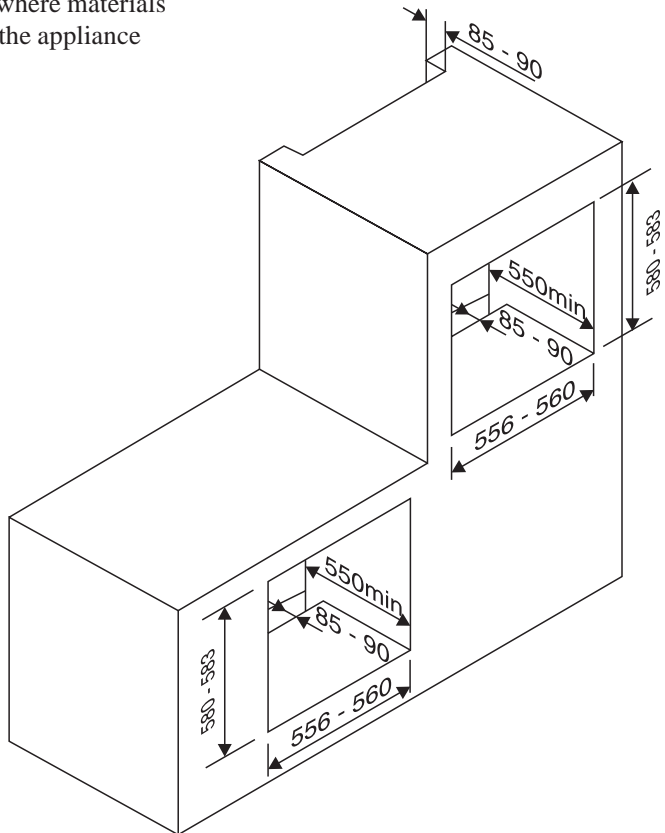

USERS GUIDE

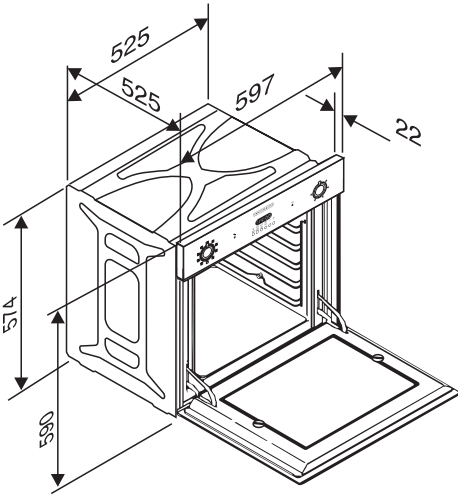

Ventilation

The appliance housing used must provide adequate ventilation in accordance with the manufacturer's recommendations as detailed in the installation diagrams above. For built-in installation, a minimum ventilation cut-out of 400cm² must be incorporated into the support shelf beneath the oven together with a 500mm x 15mm cut-out along the upper edge of the housing unit's plinth. A further ventilation space of 85 90mm must exist between the rear of the appliance and the back of the housing or an adjacent wall. If a tall housing is to be installed flush with the ceiling, a 20cm² ventilation cut -out must be provided at the top of the housing.

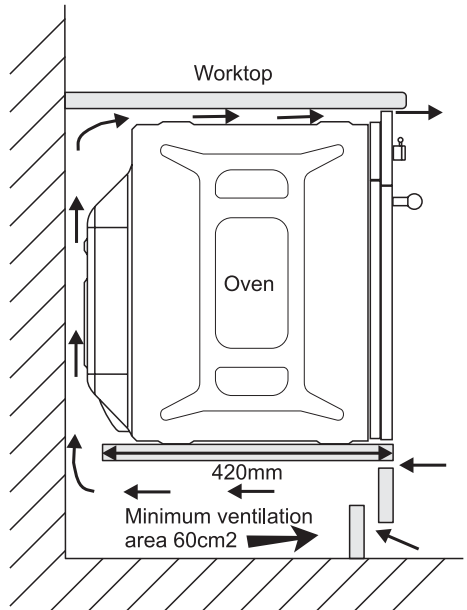

When placing the oven in the housing, do not use the oven door as a lever for lifting the oven as damage may result. Once the oven has been positioned in the housing it should be secured in place at the four corners of the oven doorframe using suitable screws (see diagram).

Technical Data

Electrical ratings

Total rated load	2.95 kW
Grill element	2.3 kW
Upper element	2.0 kW
Lower element	1.3 kW

Oven interior volumes

Volume	59 litres
--------	-----------

Overall appliance dimensions

Height	591mm
Width	598mm
Depth	525mm

Total appliance weight

Net	42 kg
Gross	39 kg

AGA CONSUMER PRODUCTS

Clarence Street, Royal Leamington Spa,
Warwickshire, CV31 2AD, England.

Tel: +44 (0) 1926 457400 Fax: +44 (0) 1926 450526

E-mail: consumers @rangemaster.co.uk